

FEATURES

- ±0.5°C (typical) accuracy from -45°C to +115°C
- Factory set trip points from 35°C to 115°C in 10°C increments
- No external components required
- Maximum temperature of 125°C
- Open-drain output (ADT6501)
- Push-pull output (ADT6502)
- Pin-selectable hysteresis of 2°C or 10°C
- Supply current of 30 µA (typical)
- Space-saving, 5-lead SOT-23 package

APPLICATIONS

- Medical equipment
- Automotive
- Cell phones
- Hard disk drives
- Personal computers
- Electronic test equipment
- Domestic appliances
- Process controls

GENERAL DESCRIPTION

The ADT6501/ADT6502 are trip point temperature switches available in a 5-lead SOT-23 package. Each part contains an internal band gap temperature sensor for local temperature sensing. When the temperature crosses the trip point setting, the logic output is activated. The ADT6501 logic output is active low and open-drain. The ADT6502 logic output is active high and push-pull. The temperature is digitized to a resolution of 0.125°C (11 bit). The factory trip point settings are 10°C apart starting from 35°C to 115°C

These devices require no external components and typically consume 30 µA supply current. Hysteresis is pin-selectable at 2°C and 10°C. The temperature switch is specified to operate over the supply range of 2.7 V to 5.5 V.

The ADT6501/ADT6502 are used for monitoring temperatures from 35°C to 115°C only. Therefore, the logic output pin becomes active when the temperature goes higher than the selected trip point temperature.

FUNCTIONAL BLOCK DIAGRAM

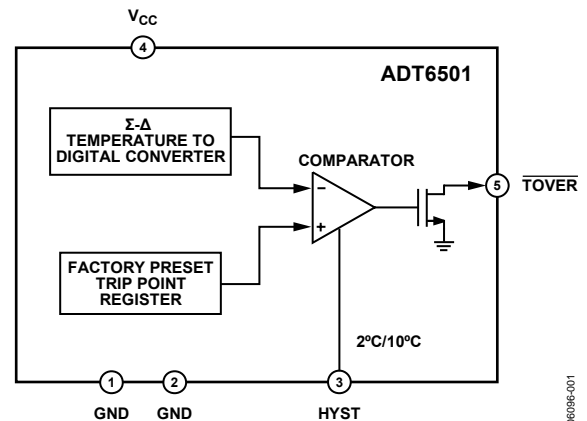

Figure 1.

PRODUCT HIGHLIGHTS

1. Σ - Δ based temperature measurement gives high accuracy and noise immunity.
2. Wide operating temperature range from -55°C to +125°C.
3. ±0.5°C typical accuracy from -45°C to +115°C.
4. Factory threshold settings from 35°C to 115°C in 10°C increments.
5. Supply voltage is 2.7 V to 5.5 V.
6. Supply current of 30 µA.
7. Space-saving, 5-lead SOT-23 package.
8. Pin-selectable temperature hysteresis of 2°C or 10°C.
9. Temperature resolution of 0.125°C.

Rev. 0

Information furnished by Analog Devices is believed to be accurate and reliable. However, no responsibility is assumed by Analog Devices for its use, nor for any infringements of patents or other rights of third parties that may result from its use. Specifications subject to change without notice. No license is granted by implication or otherwise under any patent or patent rights of Analog Devices. Trademarks and registered trademarks are the property of their respective owners.

TABLE OF CONTENTS

Features	1	Circuit Information.....	8
Applications.....	1	Converter Details	8
Functional Block Diagram	1	Factory-Programmed Threshold Range	8
General Description	1	Hysteresis Input	8
Product Highlights	1	Temperature Conversion.....	8
Revision History	2	Applications Information	9
Specifications.....	3	Thermal Response Time	9
Absolute Maximum Ratings.....	4	Self-Heating Effects.....	9
ESD Caution.....	4	Supply Decoupling	9
Pin Configuration and Function Descriptions.....	5	Temperature Monitoring.....	9
Typical Performance Characteristics	6	Outline Dimensions	11
Theory of Operation	8	Ordering Guide	11

REVISION HISTORY

9/07—Revision 0: Initial Version

SPECIFICATIONS

$T_A = -55^{\circ}\text{C}$ to $+125^{\circ}\text{C}$; $V_{CC} = 2.7\text{ V}$ to 5.5 V ; open-drain $R_{PULL-UP} = 10\text{ k}\Omega$; unless otherwise noted.

Table 1.

Parameter	Min	Typ	Max	Unit	Test Conditions/Comments
TEMPERATURE SENSOR AND ADC					
Threshold Accuracy		± 0.5	± 6	$^{\circ}\text{C}$	$T_A = -45^{\circ}\text{C}$ to -25°C
		± 0.5	± 4	$^{\circ}\text{C}$	$T_A = -15^{\circ}\text{C}$ to $+15^{\circ}\text{C}$
		± 0.5	± 4	$^{\circ}\text{C}$	$T_A = 35^{\circ}\text{C}$ to 65°C
		± 0.5	± 6	$^{\circ}\text{C}$	$T_A = 75^{\circ}\text{C}$ to 115°C
ADC Resolution		11		Bits	
Temperature Conversion Time		30		ms	Time necessary to complete a conversion
Update Rate		600		ms	Conversion started every 600 ms
Temperature Threshold Hysteresis		2		$^{\circ}\text{C}$	HYST pin = 0 V
		10		$^{\circ}\text{C}$	HYST pin = V_{CC}
DIGITAL INPUT (HYST)					
Input Low Voltage, V_{IL}			$0.2 \times V_{CC}$	V	
Input High Voltage, V_{IH}	$0.8 \times V_{CC}$			V	
DIGITAL OUTPUT (OPEN-DRAIN), ADT6501					
Output High Current, I_{OH}		10		nA	Leakage current, $V_{CC} = 2.7\text{ V}$, $V_{OH} = 5.5\text{ V}$
Output Low Voltage, V_{OL}			0.3	V	$I_{OL} = 1.2\text{ mA}$, $V_{CC} = 2.7\text{ V}$
			0.4	V	$I_{OL} = 3.2\text{ mA}$, $V_{CC} = 4.5\text{ V}$
Output Capacitance, C_{OUT}^1			10	pF	
DIGITAL OUTPUT (PUSH-PULL), ADT6502					
Output Low Voltage, V_{OL}			0.3	V	$I_{OL} = 1.2\text{ mA}$, $V_{CC} = 2.7\text{ V}$
			0.4	V	$I_{OL} = 3.2\text{ mA}$, $V_{CC} = 4.5\text{ V}$
Output High Voltage, V_{OH}	$0.8 \times V_{CC}$			V	$I_{SOURCE} = 500\text{ }\mu\text{A}$, $V_{CC} = 2.7\text{ V}$
	$V_{CC} - 1.5$			V	$I_{SOURCE} = 800\text{ }\mu\text{A}$, $V_{CC} = 4.5\text{ V}$
Output Capacitance, C_{OUT}^1			10	pF	
POWER REQUIREMENTS					
Supply Voltage	2.7		5.5	V	
Supply Current		30	50	μA	

¹ Guaranteed by design and characterization.

ABSOLUTE MAXIMUM RATINGS

Table 2.

Parameter	Rating
V _{CC} to GND	-0.3 V to +7 V
HYST Input Voltage to GND	-0.3 V to V _{CC} + 0.3 V
Open-Drain Output Voltage to GND	-0.3 V to +7 V
Push-Pull Output Voltage to GND	-0.3 V to V _{CC} + 0.3 V
Input Current on All Pins	20 mA
Output Current on All Pins	20 mA
Operating Temperature Range	-55°C to +125°C
Storage Temperature Range	-65°C to +160°C
Maximum Junction Temperature, T _{JMAX}	150.7°C
5-Lead SOT-23 (RJ-5)	
Power Dissipation ¹	$W_{MAX} = (T_{JMAX} - T_A^2)/\theta_{JA}$
Thermal Impedance ³	
θ _{JA} , Junction-to-Ambient (Still Air)	240°C/W
IR Reflow Soldering (RoHS Compliant Package)	
Peak Temperature	260°C (+0°C)
Time at Peak Temperature	20 sec to 40 sec
Ramp-Up Rate	3°C/sec maximum
Ramp-Down Rate	-6°C/sec maximum
Time 25°C to Peak Temperature	8-minute maximum

¹ Values relate to package being used on a standard 2-layer PCB. This gives a worst case θ_{JA}. Refer to Figure 2 for the maximum power dissipation vs. ambient temperature (T_A) plot.

² T_A = ambient temperature.

³ Junction-to-case resistance is applicable to components featuring a preferential flow direction, for example, components mounted on a heat sink. Junction-to-ambient resistance is more useful for air-cooled, PCB-mounted components.

Stresses above those listed under Absolute Maximum Ratings may cause permanent damage to the device. This is a stress rating only; functional operation of the device at these or any other conditions above those indicated in the operational section of this specification is not implied. Exposure to absolute maximum rating conditions for extended periods may affect device reliability.

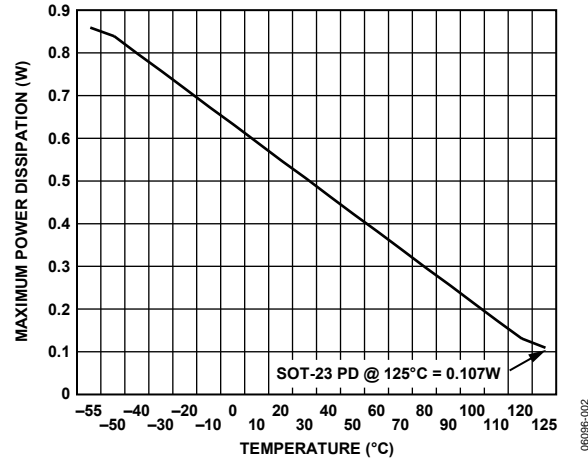

Figure 2. Maximum Power Dissipation vs. Temperature

ESD CAUTION



ESD (electrostatic discharge) sensitive device. Charged devices and circuit boards can discharge without detection. Although this product features patented or proprietary protection circuitry, damage may occur on devices subjected to high energy ESD. Therefore, proper ESD precautions should be taken to avoid performance degradation or loss of functionality.

PIN CONFIGURATION AND FUNCTION DESCRIPTIONS

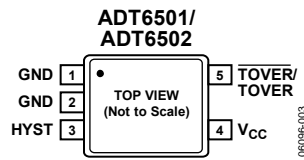

Figure 3. Pin Configuration

Table 3. Pin Function Descriptions

Pin Number		Mnemonic	Description
ADT6501	ADT6502		
1, 2	1, 2	GND	Ground.
3	3	HYST	Hysteresis Input. Connect HYST to GND for 2°C hysteresis or connect to V _{CC} for 10°C hysteresis.
4	4	V _{CC}	Supply Input (2.7 V to 5.5 V).
5	–	$\overline{\text{TOVER}}$	Open-Drain, Active-Low Output. $\overline{\text{TOVER}}$ goes low when the temperature of the part exceeds the factory-programmed threshold; must use a pull-up resistor.
–	5	TOVER	Push-Pull, Active-High Output. TOVER goes high when the temperature of the part exceeds the factory-programmed threshold.

TYPICAL PERFORMANCE CHARACTERISTICS

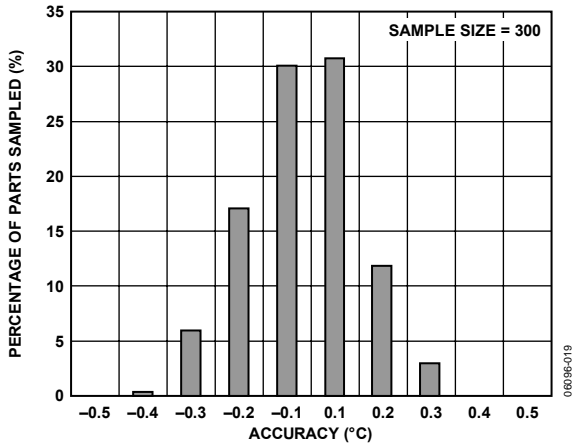

Figure 4. Trip Threshold Accuracy

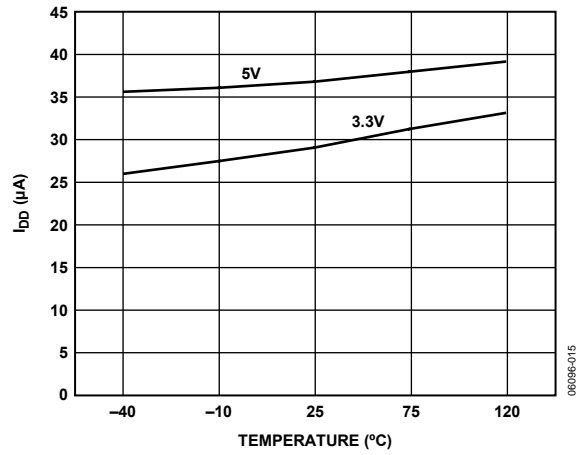

Figure 7. Operating Supply Current vs. Temperature

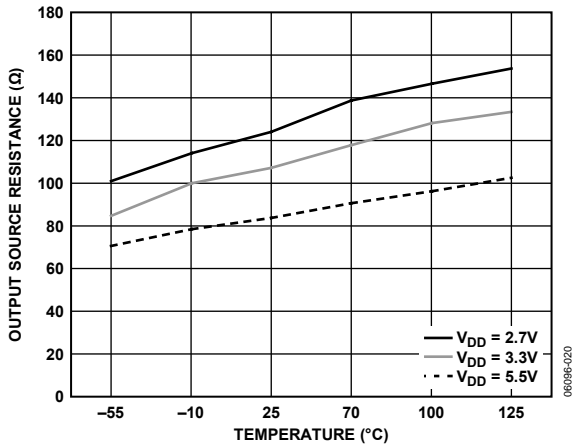

Figure 5. ADT6502 Output Source Resistance vs. Temperature

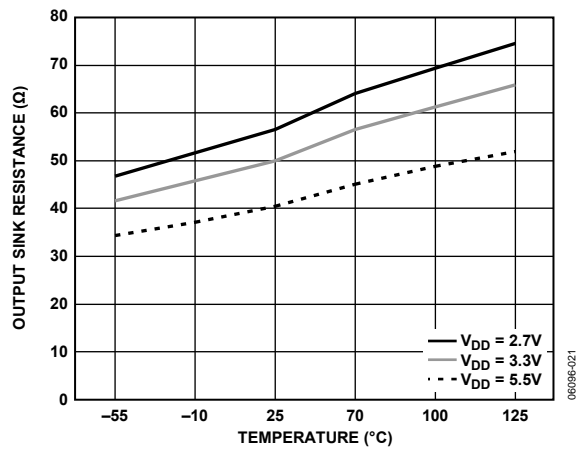

Figure 8. Output Sink Resistance vs. Temperature

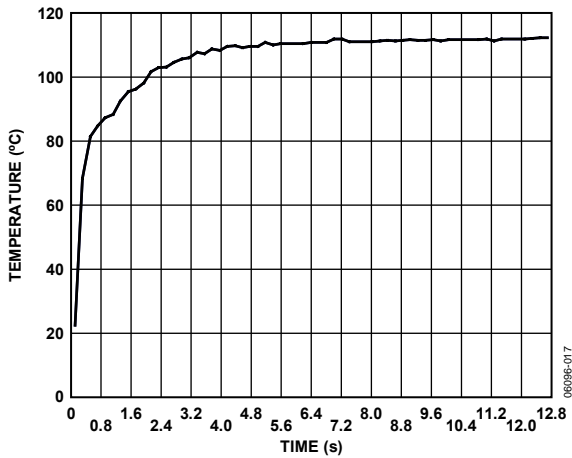

Figure 6. Thermal Step Response in Perfluorinated Fluid

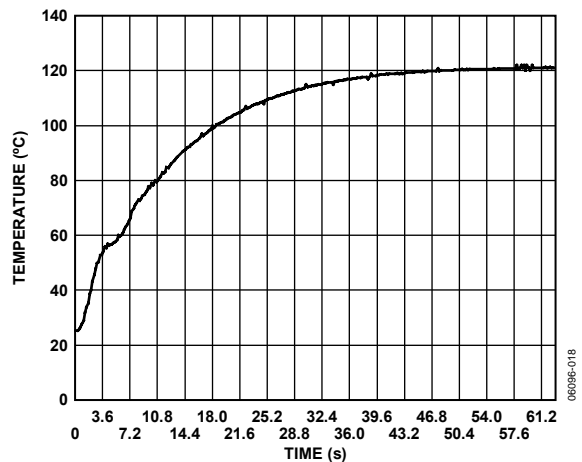

Figure 9. Thermal Step Response in Still Air

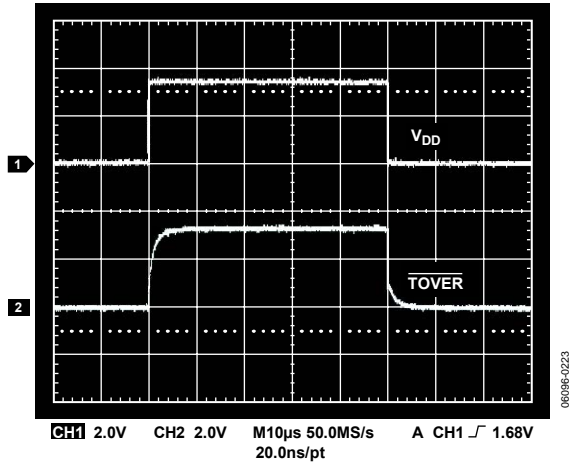

Figure 10. ADT6501 Start-Up and Power-Down

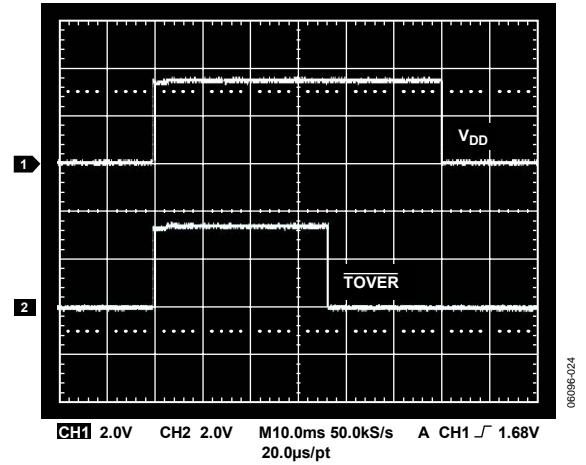

Figure 12. ADT6501 Start-Up Delay

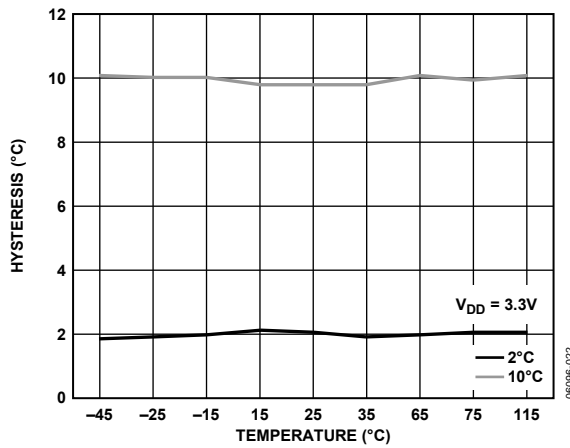

Figure 11. Hysteresis vs. Trip Temperature

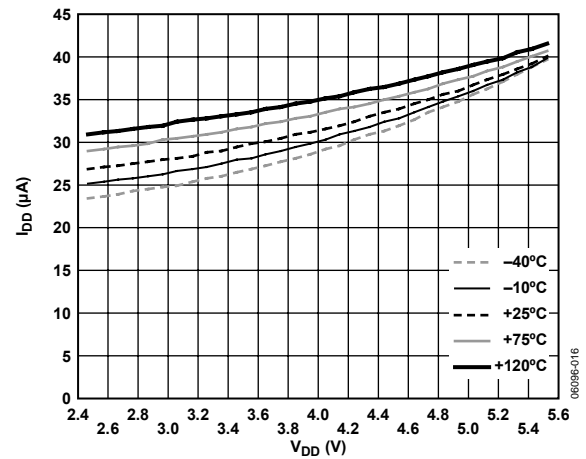

Figure 13. Operating Supply Current vs. Voltage Over Temperature

THEORY OF OPERATION

CIRCUIT INFORMATION

The ADT6501/ADT6502 are 11-bit digital temperature sensors with a 12th bit acting as the sign bit. An on-board temperature sensor generates a voltage precisely proportional to absolute temperature, which is compared to an internal voltage reference and input to a precision digital modulator. The 12-bit output from the modulator is input into a digital comparator where it is compared with a factory set trip level. The output trip pin is activated if the temperature measured is greater than the factory set trip level. Overall accuracy for the ADT6501/ADT6502 is $\pm 6^{\circ}\text{C}$ (maximum) from -45°C to $+115^{\circ}\text{C}$.

The on-board temperature sensor has excellent accuracy and linearity over the entire rated temperature range. The ADT6501 has active-low, open-drain output structures that can only sink current. The ADT6502 has active-high, push-pull output structures that can sink and source current. On power-up, the output becomes active when the first conversion is completed, which typically takes 30 ms.

The sensor output is digitized by a first-order, Σ - Δ modulator, also known as the charge balance type analog-to-digital converter (ADC). This type of converter uses time-domain oversampling and a high accuracy comparator to deliver 11 bits of effective accuracy in an extremely compact circuit.

CONVERTER DETAILS

The Σ - Δ modulator consists of an input sampler, a summing network, an integrator, a comparator, and a 1-bit digital-to-analog converter (DAC). Similar to the voltage-to-frequency converter, this architecture creates a negative feedback loop and minimizes the integrator output by changing the duty cycle of the comparator output in response to input voltage changes. The comparator samples the output of the integrator at a much higher rate than the input sampling frequency; this is called oversampling. Oversampling spreads the quantization noise over a much wider band than that of the input signal, improving overall noise performance and increasing accuracy.

FACTORY-PROGRAMMED THRESHOLD RANGE

The ADT6501/ADT6502 are available with factory set threshold levels ranging from 35°C to 115°C in 10°C temperature steps. The ADT6501 outputs are intended to interface to reset inputs of microprocessors. The ADT6502 is intended for driving circuits of applications such as fan control circuits. Table 4 lists the available temperature threshold ranges.

Table 4. Factory-Set Temperature Threshold Ranges

Device	Threshold (T_{TH}) Range
ADT6501	$35^{\circ}\text{C} < T_{TH} < 115^{\circ}\text{C}$
ADT6502	$35^{\circ}\text{C} < T_{TH} < 115^{\circ}\text{C}$

HYSTERESIS INPUT

The HYST pin is used to select a temperature hysteresis of 2°C or 10°C . The digital comparator ensures excellent accuracy for the hysteresis value. If the HYST pin is connected to V_{CC} , a hysteresis of 10°C is selected. If the HYST pin is connected to GND, a hysteresis of 2°C is selected. The HYST pin should not be left floating. Hysteresis prevents oscillation on the output pin when the temperature is approaching the trip point and after the output pin is activated. For example, if the temperature trip is 45°C and the hysteresis selected is 10°C , the temperature would have to go as low as 35°C before the output deactivates.

TEMPERATURE CONVERSION

The conversion clock for the part is generated internally. No external clock is required. The internal clock oscillator runs an automatic conversion sequence. During this automatic conversion sequence, a conversion is initiated every 600 ms. At this time, the part powers up its analog circuitry and performs a temperature conversion.

This temperature conversion typically takes 30 ms, after which time the analog circuitry of the part automatically shuts down. The analog circuitry powers up again 570 ms later, when the 600 ms timer times out and the next conversion begins. The result of the most recent temperature conversion is compared with the factory set trip point value. If the temperature measured is greater than the trip point value, the output is activated. The output is deactivated once the temperature crosses back over the trip point threshold plus whatever temperature hysteresis is selected. Figure 14 and Figure 15 show the transfer function for the output trip pin of each generic model.

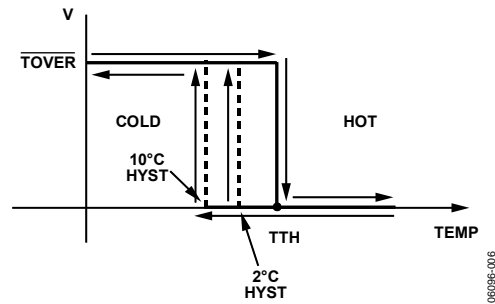

Figure 14. ADT6501 \overline{TOVER} Transfer Function

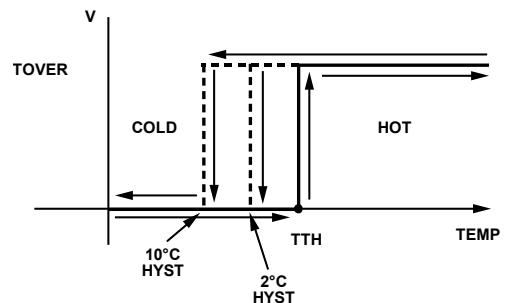

Figure 15. ADT6502 \overline{TOVER} Transfer Function

APPLICATIONS INFORMATION

THERMAL RESPONSE TIME

The time required for a temperature sensor to settle to a specified accuracy is a function of the sensor's thermal mass and the thermal conductivity between the sensor and the object being sensed. Thermal mass is often considered equivalent to capacitance. Thermal conductivity is commonly specified using the symbol Q and can be thought of as thermal resistance. It is commonly specified in units of degrees per watt of power transferred across the thermal joint. Thus, the time required for the ADT6501/ADT6502 to settle to the desired accuracy depends on the characteristics of the SOT-23 package, the thermal contact established in that particular application, and the equivalent power of the heat source. In most applications, the settling time is best determined empirically.

SELF-HEATING EFFECTS

The temperature measurement accuracy of the ADT6501 and ADT6502 can be degraded in some applications due to self-heating. Errors can be introduced from the quiescent dissipation and power dissipated when converting. The magnitude of these temperature errors depends on the thermal conductivity of the ADT6501/ADT6502 package, the mounting technique, and the effects of airflow. At 25°C, static dissipation in the ADT6501 and ADT6502 is typically 99 μ W operating at 3.3 V. In the 5-lead SOT-23 package mounted in free air, this accounts for a temperature increase due to self-heating of

$$\Delta T = P_{DISS} \times \theta_{JA} = 99 \mu\text{W} \times 240^\circ\text{C}/\text{W} = 0.024^\circ\text{C}$$

It is recommended that current dissipated through the device be kept to a minimum because it has a proportional effect on the temperature error.

SUPPLY DECOUPLING

The ADT6501/ADT6502 should be decoupled with a 0.1 μ F ceramic capacitor between V_{CC} and GND. This is particularly important when the parts are mounted remotely from the power supply. Precision analog products, such as the ADT6501/ADT6502, require well-filtered power sources. Because the parts operate from a single supply, it may seem convenient to tap into the digital logic power supply.

Unfortunately, the logic supply is often a switch-mode design, which generates noise in the 20 kHz to 1 MHz range. In addition, fast logic gates can generate glitches hundreds of mV in amplitude due to wiring resistance and inductance.

If possible, the ADT6501/ADT6502 should be powered directly from the system power supply. This arrangement, shown in Figure 16, isolates the analog section from the logic switching transients. Even if a separate power supply trace is not available, generous supply bypassing reduces supply line induced errors. Local supply bypassing that consists of a 0.1 μ F ceramic capacitor is advisable to achieve the temperature accuracy specifications. This decoupling capacitor must be placed as close as possible to the ADT6501/ADT6502 V_{CC} pin.

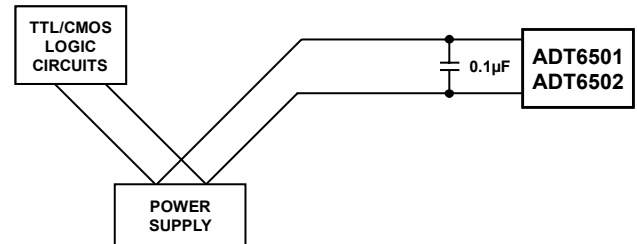

Figure 16. Separate Traces Used to Reduce Power Supply Noise

TEMPERATURE MONITORING

The ADT6501/ADT6502 are ideal for monitoring the thermal environment within electronic equipment. For example, the surface-mount package accurately reflects the exact thermal conditions that affect nearby integrated circuits.

The ADT6501/ADT6502 measure and convert the temperature at the surface of its own semiconductor chip. When the parts are used to measure the temperature of a nearby heat source, the thermal impedance between the heat source and the ADT6501/ADT6502 must be as low as possible.

As much as 60% of the heat transferred from the heat source to the thermal sensor on the ADT6501/ADT6502 die is discharged via the copper tracks, package pins, and bond pads. Of all the pins on the ADT6501/ADT6502, the GND pins transfer most of the heat. Therefore, to monitor the temperature of a heat source, it is recommended that the thermal resistance between the ADT6501/ADT6502 GND pins and the GND of the heat source be reduced as much as possible.

For example, the unique properties of the ADT6501/ADT6502 can be used to monitor a high power dissipation microprocessor. The device in its SOT-23 package is mounted directly beneath the microprocessor's pin grid array (PGA) package. The ADT6501/ADT6502 require no external characterization.

ADT6501/ADT6502

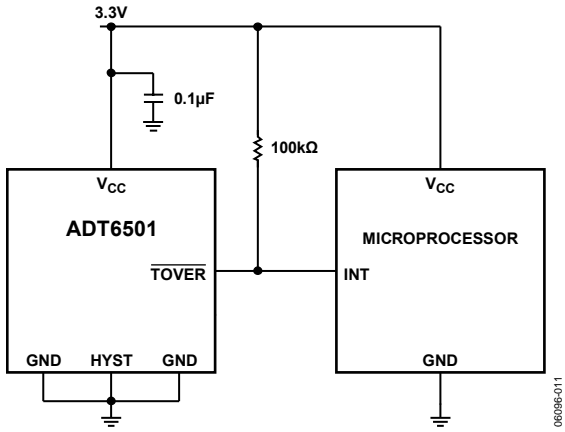

Figure 17. Microprocessor Alarm

06098-011

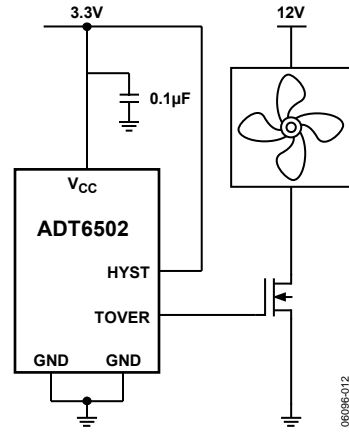

Figure 18. Overtemperature Fan Control

06098-012

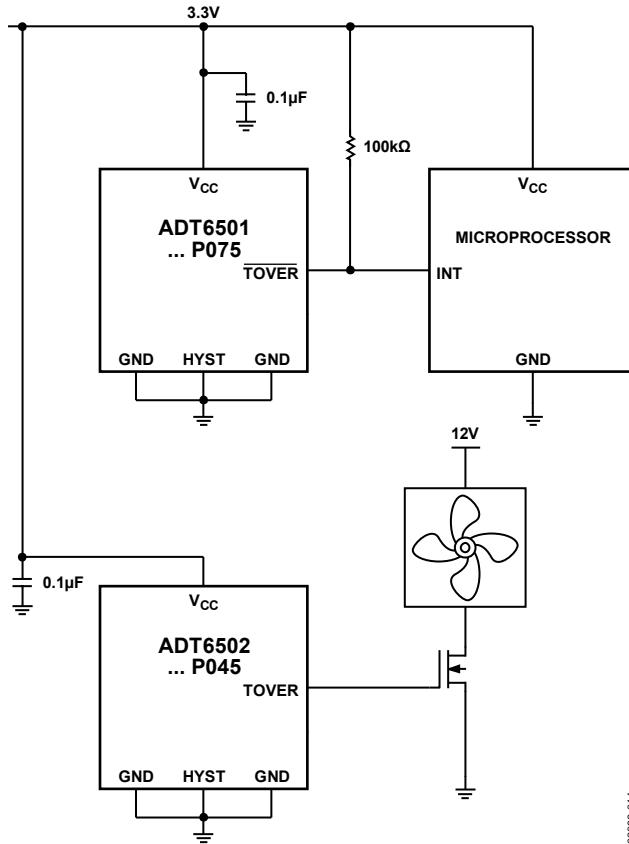
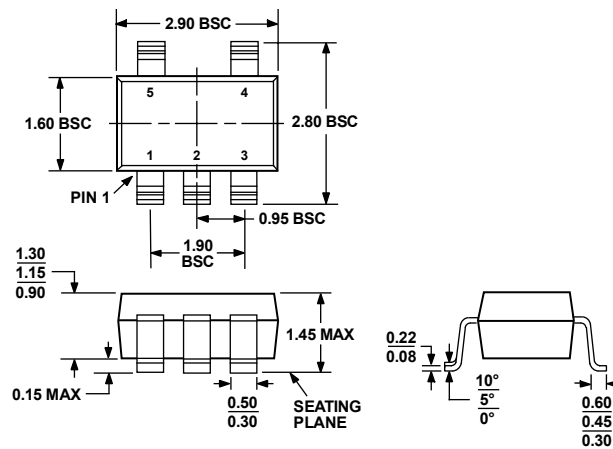

Figure 19. Fail Safe Temperature Monitor

06098-014

OUTLINE DIMENSIONS



COMPLIANT TO JEDEC STANDARDS MO-178-AA

Figure 20. 5-Lead Small Outline Transistor Package [SOT-23] (RJ-5)

Dimensions shown in millimeters

ORDERING GUIDE

Model	Threshold Temperature	Accuracy @ Threshold Temperature	Temperature Range	Package Description	Package Option	Ordering Quantity	Branding
ADT6501SRJZP035RL7 ¹	35°C	±4°C	-55°C to +125°C	5-Lead SOT-23	RJ-5	3,000	T1U
ADT6501SRJZP045RL7 ¹	45°C	±4°C	-55°C to +125°C	5-Lead SOT-23	RJ-5	3,000	T1V
ADT6501SRJZP055RL7 ¹	55°C	±4°C	-55°C to +125°C	5-Lead SOT-23	RJ-5	3,000	T0B
ADT6501SRJZP065RL7 ¹	65°C	±4°C	-55°C to +125°C	5-Lead SOT-23	RJ-5	3,000	T1W
ADT6501SRJZP075RL7 ¹	75°C	±6°C	-55°C to +125°C	5-Lead SOT-23	RJ-5	3,000	T1X
ADT6501SRJZP085RL7 ¹	85°C	±6°C	-55°C to +125°C	5-Lead SOT-23	RJ-5	3,000	T0W
ADT6501SRJZP085-RL ¹	85°C	±6°C	-55°C to +125°C	5-Lead SOT-23	RJ-5	10,000	T0W
ADT6501SRJZP095RL7 ¹	95°C	±6°C	-55°C to +125°C	5-Lead SOT-23	RJ-5	3,000	T1Y
ADT6501SRJZP105RL7 ¹	105°C	±6°C	-55°C to +125°C	5-Lead SOT-23	RJ-5	3,000	T15
ADT6501SRJZP105-RL ¹	105°C	±6°C	-55°C to +125°C	5-Lead SOT-23	RJ-5	10,000	T15
ADT6501SRJZP115RL7 ¹	115°C	±6°C	-55°C to +125°C	5-Lead SOT-23	RJ-5	3,000	T1Z
ADT6502SRJZP035RL7 ¹	35°C	±4°C	-55°C to +125°C	5-Lead SOT-23	RJ-5	3,000	T25
ADT6502SRJZP045RL7 ¹	45°C	±4°C	-55°C to +125°C	5-Lead SOT-23	RJ-5	3,000	T26
ADT6502SRJZP055RL7 ¹	55°C	±4°C	-55°C to +125°C	5-Lead SOT-23	RJ-5	3,000	T27
ADT6502SRJZP065RL7 ¹	65°C	±4°C	-55°C to +125°C	5-Lead SOT-23	RJ-5	3,000	T28
ADT6502SRJZP075RL7 ¹	75°C	±6°C	-55°C to +125°C	5-Lead SOT-23	RJ-5	3,000	T17
ADT6502SRJZP085RL7 ¹	85°C	±6°C	-55°C to +125°C	5-Lead SOT-23	RJ-5	3,000	T29
ADT6502SRJZP095RL7 ¹	95°C	±6°C	-55°C to +125°C	5-Lead SOT-23	RJ-5	3,000	T2B
ADT6502SRJZP105RL7 ¹	105°C	±6°C	-55°C to +125°C	5-Lead SOT-23	RJ-5	3,000	T2C
ADT6502SRJZP115RL7 ¹	115°C	±6°C	-55°C to +125°C	5-Lead SOT-23	RJ-5	3,000	T2D

¹ Z = RoHS Compliant Part.

ADT6501/ADT6502

NOTES